

THE PROPERTY OF THE DRAWING IS ESTABLISHED BY LAW. IT IS FORBIDDEN TO PRODUCE OR SHOW IT TO THIRD PART. WITHOUT A WRITTEN AGREEMENT.

A	04/03/2019	Minarini	Aggiornamento Tavola	
Indice	Data	Autore	Commento	

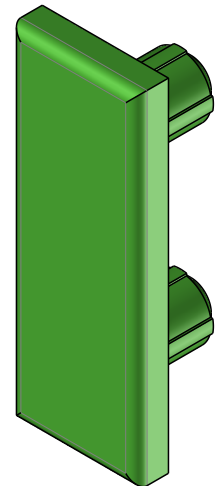

	<p>Incollaggio Parte in Gomma su Alluminio</p> <ol style="list-style-type: none"> 1) Pulitura Superficiale Parte in Gomma con Carta Vetrata 2) Pulitura Superficiale Alluminio con Carta Vetrata 3) Applicazione Primer LOCTITE 770 sulla Gomma 4) Applicazione Collante LOCTITE 406 su Alluminio 5) Applicazione Gomma su Parte in Alluminio 	<p>Glue bonding procedure pad Rubber in Lay on pad holder Aluminium</p> <ol style="list-style-type: none"> 1) Surface cleaning of Rubber in Lay with sandpaper 2) Surface cleaning of Aluminium with sandpaper 3) Put Primer LOCTITE 770 on pad RUBBER in Lay 4) Put glue LOCTITE 406 on pad holder Aluminium 5) Stick pad Rubber in Lay on pad holder Aluminium
	<p>Klebeverfahren Pad Gummi auf Padhalter Aluminium</p> <ol style="list-style-type: none"> 1) Oberflächenreinigung Gummi mit Schleifpapier 2) Oberflächenreinigung Aluminium mit Schleifpapier 3) Anbringen von Primer LOCTITE 770 auf Pad Gummi 4) Anbringen von LOCTITE 406 auf Padhalter Aluminium 5) Aufkleben von Pad Gummi auf Padhalter Aluminium 	<p>Como pegar el tampón Goma sobre el adaptador para Aluminio</p> <ol style="list-style-type: none"> 1) Limpieza con esmeril de la superficie del tampón Goma 2) Limpieza con esmeril de la superficie de Aluminio 3) Aplicación primer LOCTITE 770 sobre el tampón Goma 4) Aplicación pegamento LOCTITE 406 sobre el adaptador para tampón Aluminio 5) Aplicación del tampón Goma sobre el adaptador para tampón Aluminio

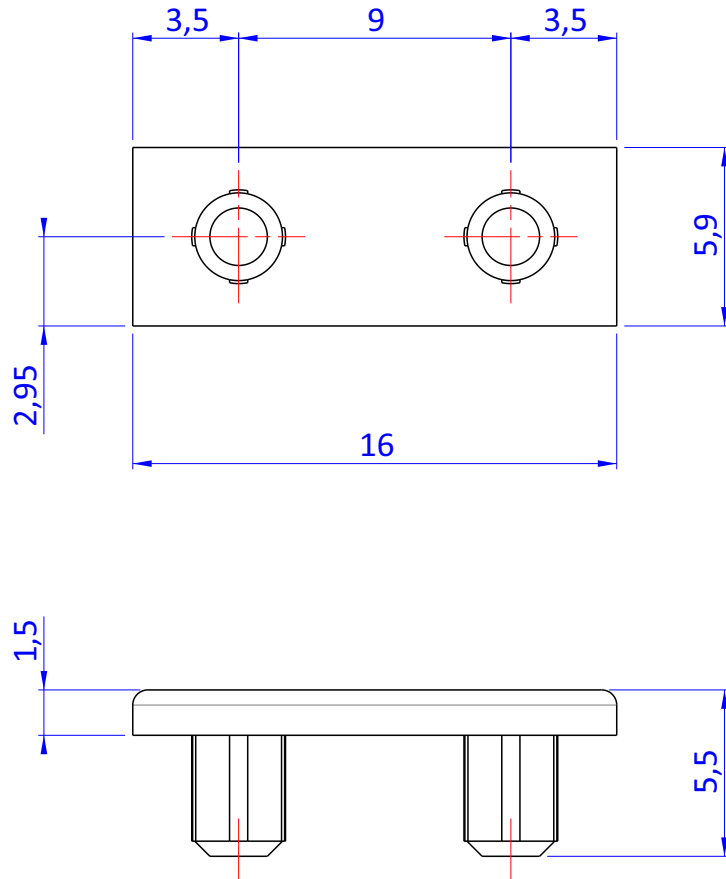
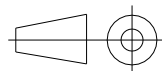

DESIGNED FROM	REVIEW	SCALA
FPS Automation	A	5 : 1
DATE	WEIGHT	
01/08/2017	0,000kg	
CODE		
GZA.10.08.6.V		

Format A4
UNI 936-76

GENERAL TOLERANCE	MATERIALE	VITON
UNI - ISO 2768	TRATTAMENTO	Chrome Plating
CLASSE f		